

| REVISION | | | |
|----------|-------------|------|----|
| REV | DESCRIPTION | DATE | BY |

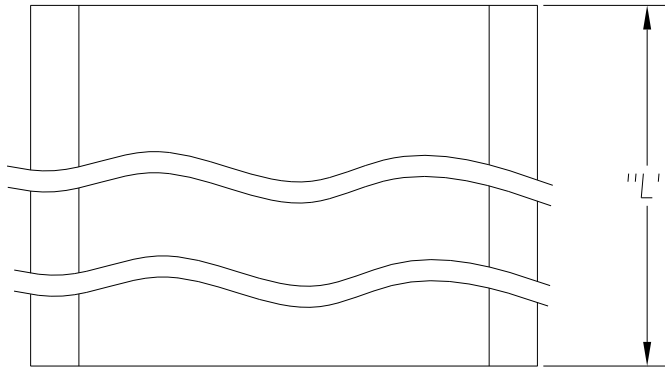

2ND ROLLING OPERATION
INSERTED WITH WOOD AND RUBBER

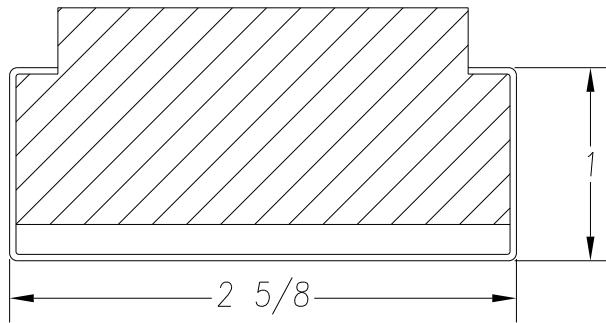

1ST ROLLING OPERATION

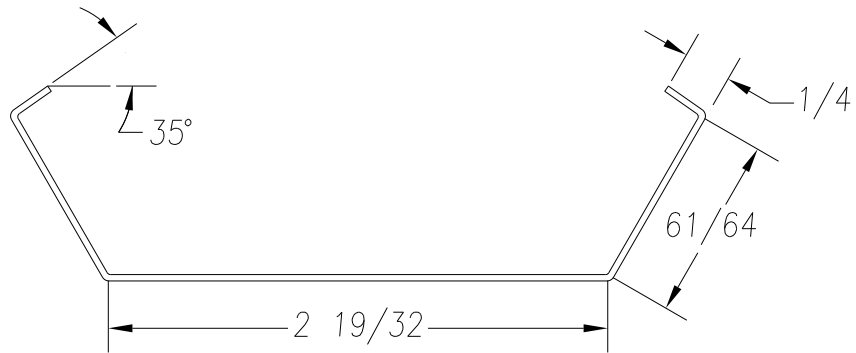

SEE PO FOR MATERIAL TYPE AND FINISH
FOR LENGTH DIMENSION ("L"), SEE PURCHASE ORDER.
LENGTH TOLERANCE: LESS THAN 60": $\pm 1/16"$ LESS THAN 120": $\pm 1/8"$, 120" OR GREATER: $\pm 1/4"$
MAXIMUM BURR NOT TO EXCEED 10% OF MAT'L THICKNESS WITH THE EXCEPTION OF CUT ENDS,
WHICH MAY HAVE BURR EXCEEDING THIS AMOUNT.
FINISHED PART MAY EXHIBIT TYPICAL ROLL FORMED END CUT DISTORTION.
PROFILE DIMENSIONS TO BE MEASURED 2" OR GREATER FROM CUT ENDS.

| | | | | | |
|--|--|------------------|---|---------|------|
| MATERIAL | GAUGE 20 | WIDTH | FINISH | | |
| ALLOY | THIS DRAWING AND ITS CONTENTS ARE CONFIDENTIAL AND ARE NOT TO BE REPRODUCED, USED OR COPIED IN WHOLE OR IN PART OR DISCLOSED TO OTHERS EXCEPT AS AUTHORIZED BY SAMSON ROLL FORM PRODUCTS | | SAMSON ROLL FORMED PRODUCTS PH 847-965-6700 FAX 847-965-8950 6101 W OAKTON ST. SKOKIE, IL 60077 | | |
| TEMPER | | | | | |
| WT. PER M/FT. | | | | | |
| -TOLERANCES- NOT INDICATED .XXX ± 0.10 .XX ± 0.030 .X ± 0.060 FRACTIONAL $\pm 1/32$ ANGLES $\pm 1^\circ$ | DRAWN BY: K.P.B. 1/18/91 | DATE: 1/18/91 | TITLE FLOORING CHANNEL | | |
| | CHECKED BY: | DATE: | SIZE B | | |
| | DO NOT SCALE THIS DRAWING | SCALE: FULL | DRAWING # S-1786 | SHEET # | REV. |