

REVISION			
REV	DESCRIPTION	DATE	BY

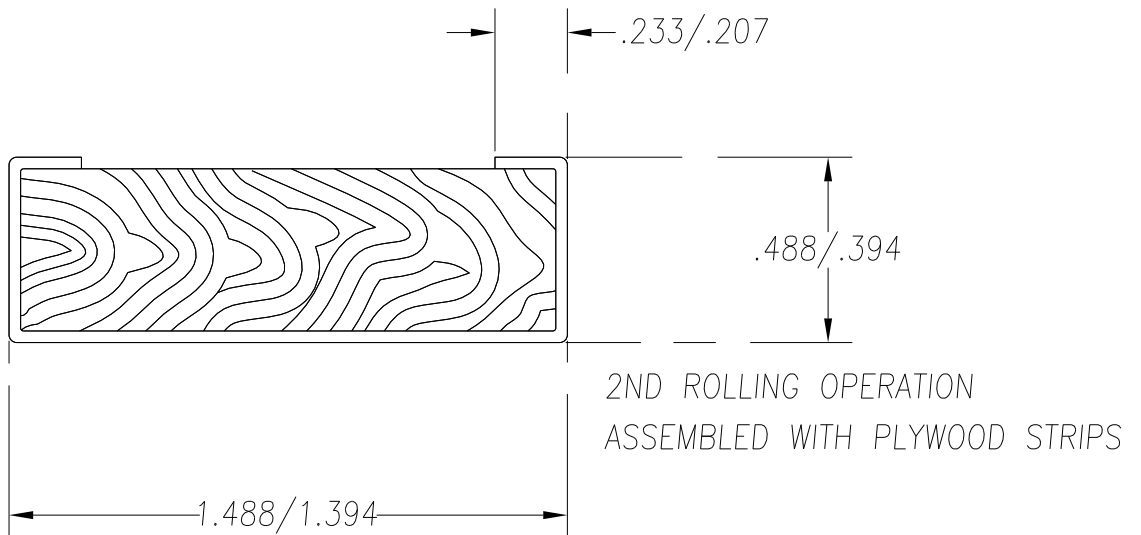
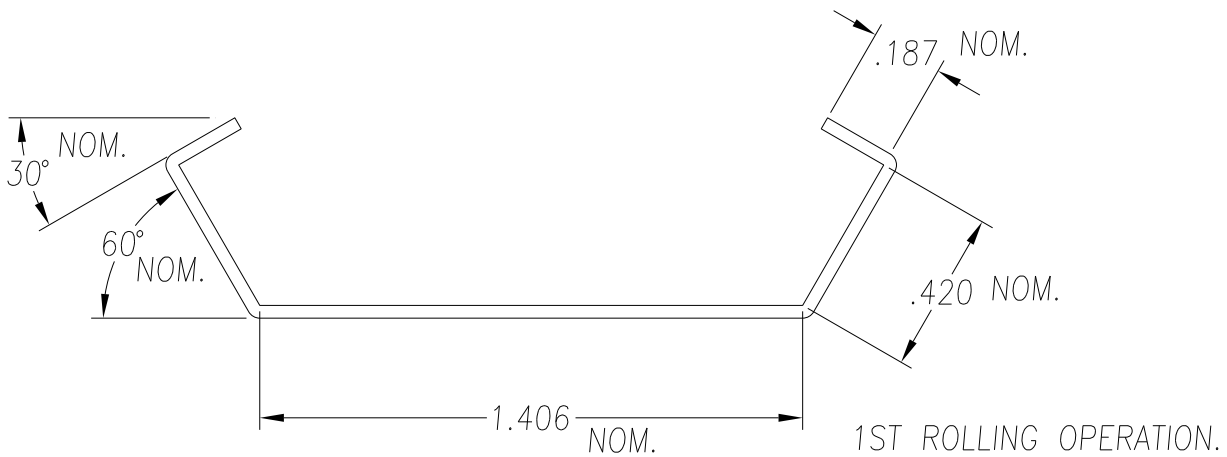

TOLERANCE LIMITS REFLECT MAX/MIN CONDITIONS OF WOOD, METAL AND MFG. TOLERANCES.

SEE PO FOR MATERIAL TYPE AND FINISH

FOR LENGTH DIMENSION ("L"), SEE PURCHASE ORDER.

LENGTH TOLERANCE: LESS THAN 60": $\pm 1/16"$ LESS THAN 120": $\pm 1/8"$, 120" OR GREATER: $\pm 1/4"$

MAXIMUM BURR NOT TO EXCEED 10% OF MAT'L THICKNESS WITH THE EXCEPTION OF CUT ENDS, WHICH MAY HAVE BURR EXCEEDING THIS AMOUNT.

FINISHED PART MAY EXHIBIT TYPICAL ROLL FORMED END CUT DISTORTION.

PROFILE DIMENSIONS TO BE MEASURED 2" OR GREATER FROM CUT ENDS.

MATERIAL	GAUGE 21	WIDTH	FINISH
COATING	THIS DRAWING AND ITS CONTENTS ARE CONFIDENTIAL AND ARE NOT TO BE REPRODUCED, USED OR COPIED IN WHOLE OR IN PART OR DISCLOSED TO OTHERS EXCEPT AS AUTHORIZED BY SAMSON ROLL FORM PRODUCTS		SAMSON ROLL FORMED PRODUCTS
TEMPER			
WT. PER M/FT.			
	DRAWN BY: D.R.M. 4/2/81	DATE:	TITLE NAILING STRIP.
	CHECKED BY:	DATE:	SIZE B
	DO NOT SCALE THIS DRAWING	SCALE: 2:1	CUSTOMER
-TOLERANCES- NOT INDICATED .XXX $\pm .010$.XX $\pm .030$.X $\pm .060$ FRACTIONAL $\pm 1/32$ ANGLES $\pm 1^\circ$	DRAWING # S-1622	SHEET #	REV.
			6101 W OAKTON ST. SKOKIE, IL 60077