

REVISION			
REV	DESCRIPTION	DATE	BY

V  
ACTUAL SIZE.

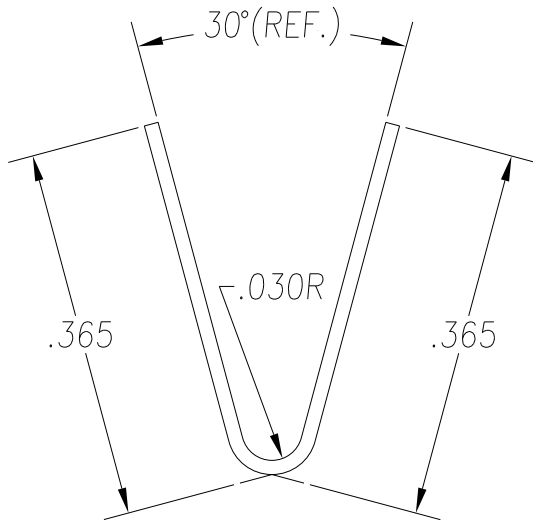
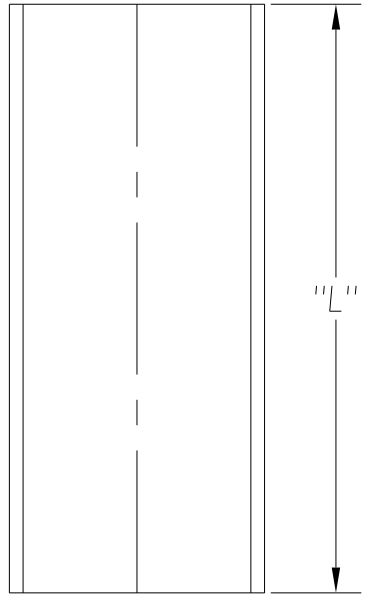

SEE PO FOR MATERIAL TYPE AND FINISH  
 FOR LENGTH DIMENSION ("L"), SEE PURCHASE ORDER.  
 LENGTH TOLERANCE: LESS THAN 60":  $\pm 1/16"$  LESS THAN 120":  $\pm 1/8"$ , 120" OR GREATER:  $\pm 1/4"$   
 MAXIMUM BURR NOT TO EXCEED 10% OF MAT'L THICKNESS WITH THE EXCEPTION OF CUT ENDS,  
 WHICH MAY HAVE BURR EXCEEDING THIS AMOUNT.  
 FINISHED PART MAY EXHIBIT TYPICAL ROLL FORMED END CUT DISTORTION.  
 PROFILE DIMENSIONS TO BE MEASURED 2" OR GREATER FROM CUT ENDS.

MATERIAL	GAUGE 28	WIDTH	FINISH
COATING	THIS DRAWING AND ITS CONTENTS ARE CONFIDENTIAL AND ARE NOT TO BE REPRODUCED, USED OR COPIED IN WHOLE OR IN PART OR DISCLOSED TO OTHERS EXCEPT AS AUTHORIZED BY SAMSON ROLL FORM PRODUCTS	SAMSON ROLL FORMED PRODUCTS	
TEMPER			
WT. PER M/FT.			
-TOLERANCES- NOT INDICATED .XXX $\pm .015$ .XX $\pm .030$ .X $\pm .060$ FRACTIONAL $\pm 1/32$ ANGLES $\pm 1^\circ$	DRAWN BY: D.M. 2/3/81	DATE:	TITLE "V"SECTION.
	CHECKED BY: B.B.B.	DATE:	SIZE A
	DO NOT SCALE THIS DRAWING	SCALE: 5:1	DRAWING # S-1619
			SHEET #
			REV.