

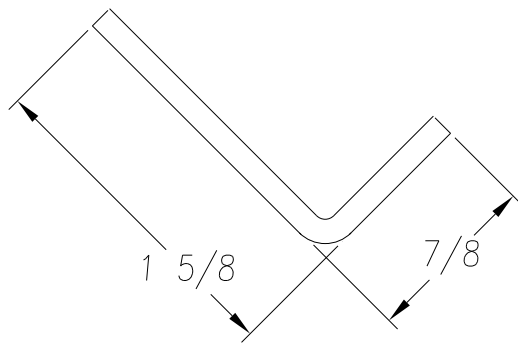

REVISION			
REV	DESCRIPTION	DATE	BY

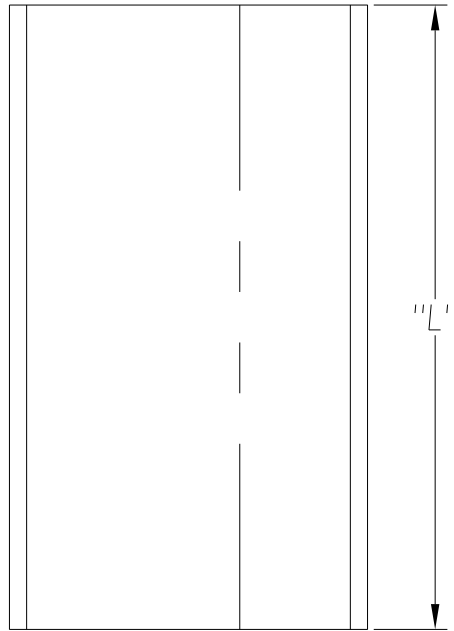

SEE PO FOR MATERIAL TYPE AND FINISH  
 FOR LENGTH DIMENSION ("L"), SEE PURCHASE ORDER.  
 LENGTH TOLERANCE: LESS THAN 60":  $\pm 1/16"$  LESS THAN 120":  $\pm 1/8"$ , 120" OR GREATER:  $\pm 1/4"$   
 MAXIMUM BURR NOT TO EXCEED 10% OF MAT'L THICKNESS WITH THE EXCEPTION OF CUT ENDS,  
 WHICH MAY HAVE BURR EXCEEDING THIS AMOUNT.  
 FINISHED PART MAY EXHIBIT TYPICAL ROLL FORMED END CUT DISTORTION.  
 PROFILE DIMENSIONS TO BE MEASURED 2" OR GREATER FROM CUT ENDS.

MATERIAL		GAUGE 12	WIDTH		FINISH			
COATING		THIS DRAWING AND ITS CONTENTS ARE CONFIDENTIAL AND ARE NOT TO BE REPRODUCED, USED OR COPIED IN WHOLE OR IN PART OR DISCLOSED TO OTHERS EXCEPT AS AUTHORIZED BY SAMSON ROLL FORM PRODUCTS			SAMSON ROLL FORMED PRODUCTS			
TEMPER							PH 847-965-6700 FAX 847-965-8950	
WT. PER M/FT.							6101 W OAKTON ST. SKOKIE, IL 60077	
-TOLERANCES- NOT INDICATED .XXX $\pm 0.10$ .XX $\pm 0.30$ .X $\pm 0.60$ FRACTIONAL $\pm 1/32$ ANGLES $\pm 1^\circ$ STRAIGHTNESS .015"/FOOT TWIST 1"/FOOT		DRAWN BY: L.S.B. 7-25-11		DATE:		TITLE: ANGLE		
		CHECKED BY:		DATE:		SIZE: A	CUSTOMER:	
DO NOT SCALE THIS DRAWING		SCALE: 1:1	DRAWING # S-1586		SHEET #		REV.	