

| REVISION | | | |
|----------|-------------|------|----|
| REV | DESCRIPTION | DATE | BY |

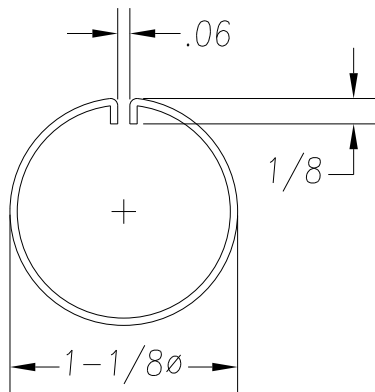
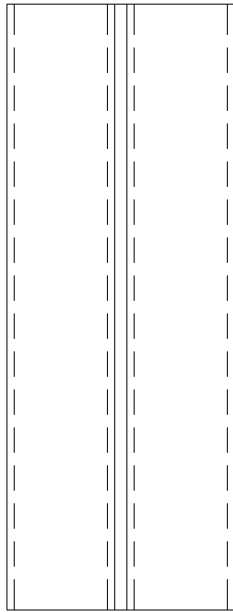

SEE PURCHASE ORDER FOR MATERIAL TYPE AND FINISH
 FOR LENGTH DIMENSION ("L"), SEE PURCHASE ORDER.
 LENGTH TOLERANCE: LESS THAN 60": $\pm 1/16$, LESS THAN 120": $\pm 1/8$ ", 120" OR GREATER: $\pm 1/4$ "
 MAXIMUM BURR NOT TO EXCEED 10% OF MAT'L THICKNESS WITH THE EXCEPTION OF CUT ENDS,
 WHICH MAY HAVE BURR EXCEEDING THIS AMOUNT.
 PROFILE MAY EXHIBIT TYPICAL ROLL FORMED END FLARE UP TO 3" FROM ENDS.
 PART TO BE MEASURED 3" OR GREATER FROM CUT ENDS.

| | | | |
|--|--|-----------------------------|-----------|
| MATERIAL | GAUGE 20 | WIDTH | FINISH |
| ALLOY | THIS DRAWING AND ITS CONTENTS ARE CONFIDENTIAL AND ARE NOT TO BE REPRODUCED, USED OR COPIED IN WHOLE OR IN PART OR DISCLOSED TO OTHERS EXCEPT AS AUTHORIZED BY SAMSON ROLL FORM PRODUCTS | SAMSON ROLL FORMED PRODUCTS | |
| TEMPER | | | |
| WT. PER M/FT. | | | |
| -TOLERANCES- NOT INDICATED .XXX $\pm .010$.XX $\pm .030$.X $\pm .060$ FRACTIONAL $\pm 1/32$ ANGLES $\pm 1^\circ$ | DRAWN BY: K.P.B. 6/9/89 | DATE: | TITLE |
| | CHECKED BY: | DATE: | SIZE A |
| DO NOT SCALE THIS DRAWING | SCALE: FULL | DRAWING # S-1397 | CUSTOMER |
| | | SHEET # | REV. |