

REVISION			
REV	DESCRIPTION	DATE	BY

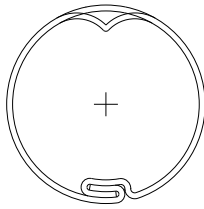

ACTUAL  
SIZE

DIMPLE FROM CUT-OFF OPERATION  
PERMITTED ON BOTH ENDS OF TUBE  
(OPPOSITE SIDE OF LOCK SEAM ONLY)

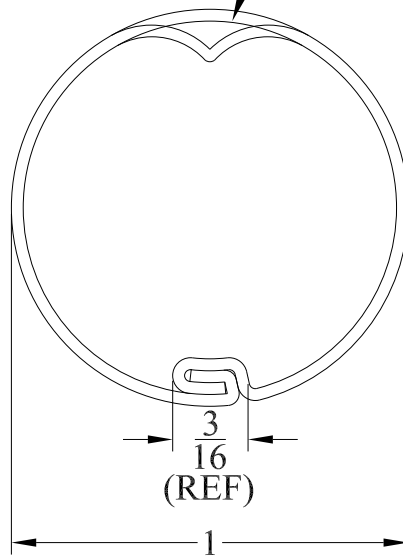

SEE PURCHASE ORDER FOR MATERIAL TYPE AND FINISH  
FOR LENGTH DIMENSION ("L"), SEE PURCHASE ORDER.  
LENGTH TOLERANCE: LESS THAN 60":  $\pm 1/16$ , LESS THAN 120":  $\pm 1/8$ ", 120" OR GREATER:  $\pm 1/4$ "  
MAXIMUM BURR NOT TO EXCEED 10% OF MAT'L THICKNESS WITH THE EXCEPTION OF CUT ENDS,  
WHICH MAY HAVE BURR EXCEEDING THIS AMOUNT.  
PART TO BE MEASURED 3" OR GREATER FROM CUT ENDS.

MATERIAL	GAUGE <b>28</b>	WIDTH	FINISH
COATING	THIS DRAWING AND ITS CONTENTS ARE CONFIDENTIAL AND ARE NOT TO BE REPRODUCED, USED OR COPIED IN WHOLE OR IN PART OR DISCLOSED TO OTHERS EXCEPT AS AUTHORIZED BY SAMSON ROLL FORM PRODUCTS	SAMSON ROLL FORMED PRODUCTS	
TEMPER			
WT. PER M/FT.		PH 847-965-6700 FAX 847-965-8950 6101 W OAKTON ST. SKOKIE, IL 60077	
-TOLERANCES- NOT INDICATED .XXX $\pm 0.10$ .XX $\pm 0.030$ .X $\pm 0.060$ FRACTIONAL $\pm 1/32$ ANGLES $\pm 1^\circ$	DRAWN BY: <b>E.M. 1/17/03</b>	DATE:	TITLE <b>1" RD. LOCKSEAM TUBE</b>
	CHECKED BY:	DATE:	SIZE A
DO NOT SCALE THIS DRAWING	SCALE: <b>1:1</b>	DRAWING # <b>S-1386</b>	CUSTOMER
		SHEET #	REV.