

REVISION		DATE	BY
REV	DESCRIPTION		

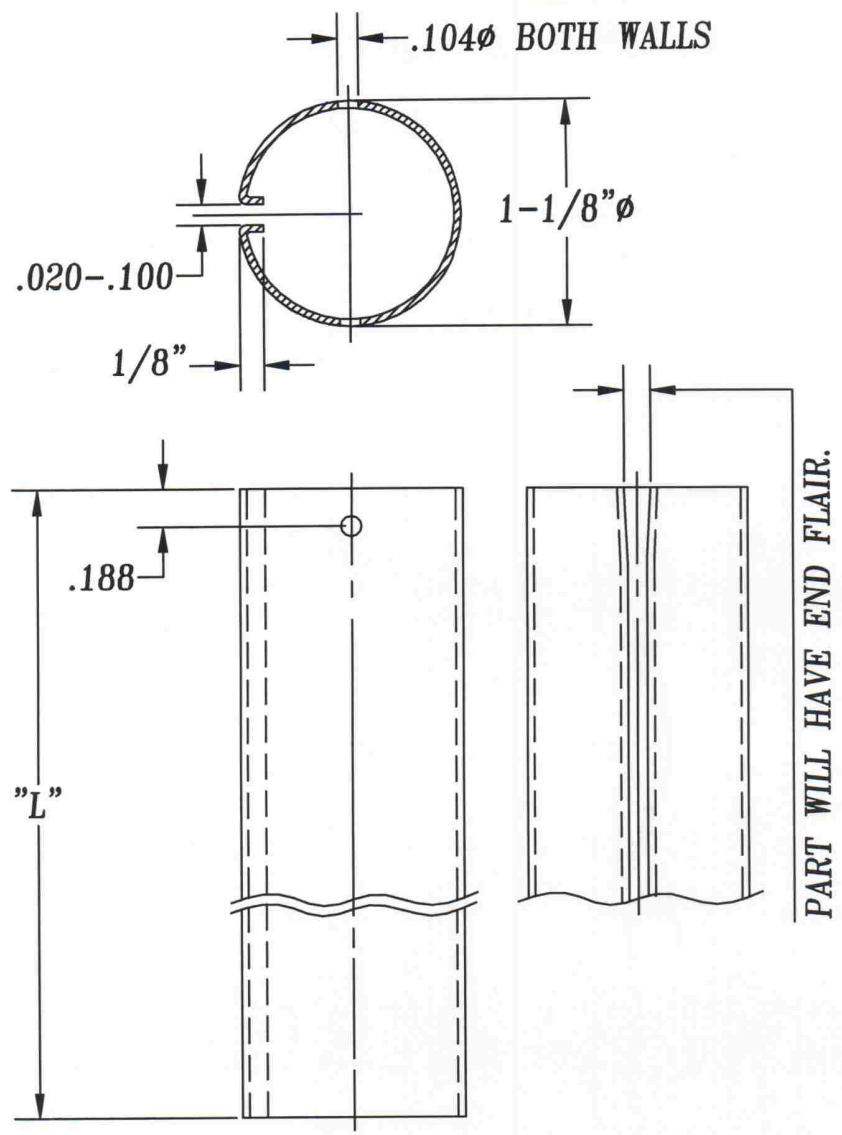

MAXIMUM BURR NOT TO EXCEED 10% OF MAT'L THICKNESS WITH THE EXCEPTION OF CUT ENDS, WHICH MAY HAVE BURR EXCEEDING THIS AMOUNT.  
 FINISHED PART MAY EXHIBIT TYPICAL ROLL FORMED END FLARE UP TO TWO INCHES FROM ENDS. PROFILE DIMENSIONS TO BE MEASURED 2" OR GREATER FROM CUT ENDS.  
 FOR FINISHED LENGTH DIMENSION("L"), REFER TO PURCHASE ORDER.  
 LENGTH TOLERANCE; LESS THAN 60":  $\pm 1/16$ , 60" TO 120"  $\pm 1/8$ ", GREATER THAN 120":  $+1/-0$

MATERIAL <b>C.R.S. C.Q.</b>	GAUGE <b>.035±.003</b>	WIDTH	FINISH
ALLOY	THIS DRAWING AND ITS CONTENTS ARE CONFIDENTIAL AND ARE NOT TO BE REPRODUCED, USED OR COPIED IN WHOLE OR IN PART OR DISCLOSED TO OTHERS EXCEPT AS AUTHORIZED BY SAMSON ROLL FORM PRODUCTS	<b>SAMSON ROLL FORMED PRODUCTS</b>	
TEMPER			
WT. PER M/FT.		PH 847-965-6700 FAX 847-965-8950 6101 W OAKTON ST. SKOKIE, IL 60077	
-TOLERANCES- NOT INDICATED .XXX ±.015 .XX ±.030 .X ±.060 FRACTIONAL ±1/32 ANGLES ±1°	DRAWN BY: <b>B.B.B. 9/20/89</b>	DATE:	TITLE <b>OPEN SEAM TUBE</b>
	CHECKED BY:	DATE:	SIZE <b>A</b>
	DO NOT SCALE THIS DRAWING	SCALE: <b>FULL</b>	DRAWING # <b>S-1397-1</b>
		SHEET #	REV.